



Continuous level transmitter for high temperature, series 450/451/452 ⊕ 453

INSTRUCTION MANUAL - English

Thank you for purchasing 450/451/452 + 453 series level transmitter.

Before using the device, please read carefully this manual, and keep it in a safe place, for future use.

1 - Description

450/451/452 series are capacitive continuous level transmitters for solid and liquid materials. The material to be controlled can be good electric conductor, or insulating, like water, oil, diesel fuel, powders in general. They cannot be used with inflammable liquids, but they can be used with diesel fuel at $T < 55^{\circ}\text{C}$.

Rugged and compact, the **450/451/452** series give an output current signal, proportional to the product level, with 2/3 wires connection.

2 - Technical characteristics

- dimensions are in mm:

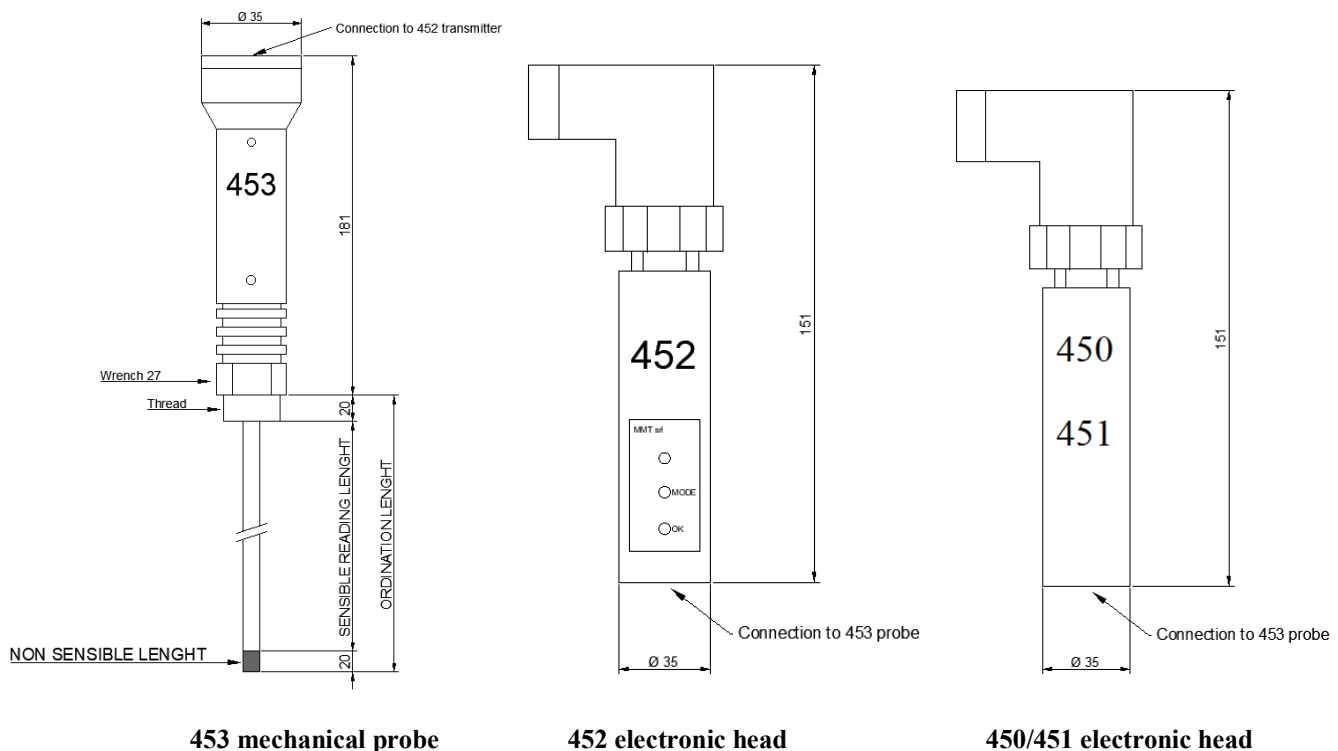

453 mechanical probe

452 electronic head

450/451 electronic head

Drawing #1

450-451-452

- Power supply: 24Vdc -15% ÷ +20%
- protected against power supply reversal
- Output Signal: 4÷20 [mA]
- R max: 500 omh
- absorption: 1,25 VA
- electric wiring: DIN 43650A
- precision: 0,5% f.s. after calibration, at 25°C
- 451/452: three wires; 450: two wires
- 450 (two wires): calibration not possible in field
- 451 (three wires); calibration not possible in field
- 452 (three wires); calibration possible in field

453

- thread: 1/2" gas
- covering 3mm thick PTFE food compliant
- stainless steel body
- weight: 1000 g [per L = 500 mm]
- pressure ≤ 32 bar
- temperature: 239 °C on the electrode
- plug: 20mm not-sensitive end, at the bottom



3 - Matching order codes

Depending on the length, refer to the following table for the correct matching between the 453 series probe and the 450/451/452 series electronic heads.

length	453(probe)	452(head)	451(head)	450(head)
350÷500 mm	453-505-00	452-010-04	451-005-04	450-005-04
501÷1000 mm	453-510-00		451-010-04	450-010-04
1001÷1500 mm	453-515-00	452-015-04	451-015-04	450-015-04
1501÷1900 mm	453-520-00	452-020-04	451-020-04	450-020-04

Warning: incorrect pairing between the probe and the electronic head can lead to errors in level measurement, reduction of precision; impossibility of calibration.

4 - Working

Once the transmitter has been installed, it generates a normalized 4÷20 mA d.c. signal proportional to the material level in the tank, with 4mA probe covered for 1.5% of the length and 20mA with probe covered for 99% of the length.

5 - Installation and use

Do not install the probe in the open air without suitable protection against atmospheric agents.

5.1 - Mechanical assembly

- The transmitter must be installed according to the following drawing:

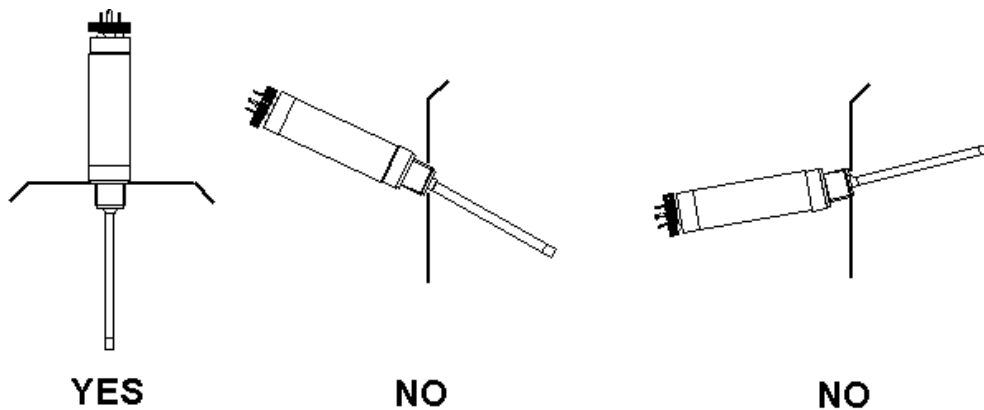

Drawing #2

Consider the thermal stretch of the PTFE coating could be 20 ÷ 30mm.

For the use of the output signal with a regulator or PLC consider current values (mA) read during normal use condition.

The transmitter must be mounted in the tank, in vertical position, so that the tank sides aren't in contact with the probe.

The minimum measurement level (4mA) is about 1,5% of the probe height.

The maximum measurement level (20mA) is about 99% of the probe height.

The following drawing is an example for 1m long probe.

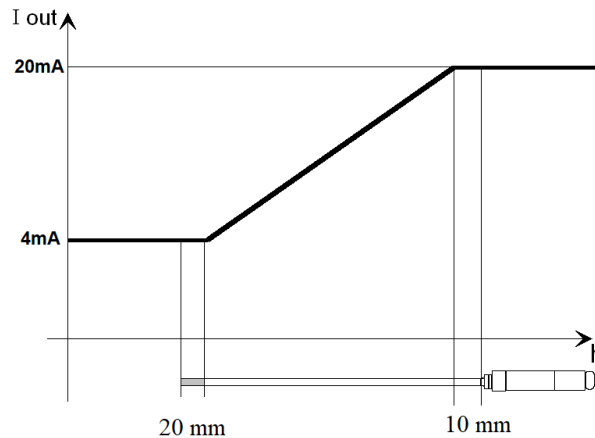

5.2 - Electric wiring

Warning!

Avoid installing the probe before the end of the pipe welding work on the system.

The electric/electrostatic discharges produced could generate dangerous currents along the masses and therefore cause irreversible damage to the electronic part of the probe, even if it had not yet been connected/powerd.

- **Before powering the device, be sure that the power supply voltage is in the range 24 Vdc -15% ÷ 20% .**
 - Wire the transmitter to the power supply and to the current loop receiver, according the following drawing. It is recommended the use of a shielded cable, especially for long distances.
- The maximum current loop load is 500Ω.

Conductive or insulating liquids in metal tank

Do not interpose flange or electric insulating gaskets (like PTFE) between the thread ½" of the probe and the surface/body of the tank; the ground of the tank must be in contact with the thread ½" of the probe. Anyway, connect electrically the terminal GND of the transmitter with the tank ground.

Conductive liquids in insulating tank

You must insert inside the same tank a metallic electrode (good electric conductor) that has to be always in contact with the material to be measured, also to the least desired level; this electrode must have the same length of the probe and diameter 4mm, and must be electrically connected to the terminal GND of the transmitter.

Insulating liquids in non metal tank

If the product to be measured is an insulating liquid and the tank is also insulating, it is necessary to place a metal tube coaxial to the antenna of the 453 probe, along its entire length. Electrically connect this tube to the GND terminal of the transmitter.



5.3 - Wiring diagram (three wires) for 451/452 with user not galvanically isolated

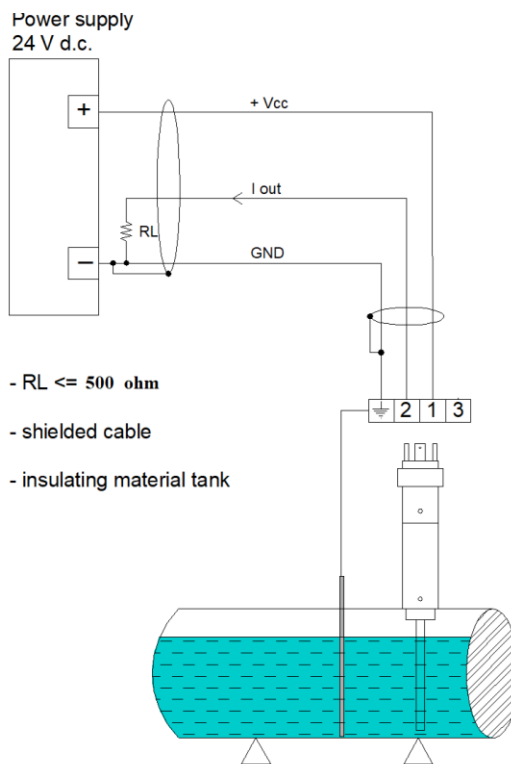
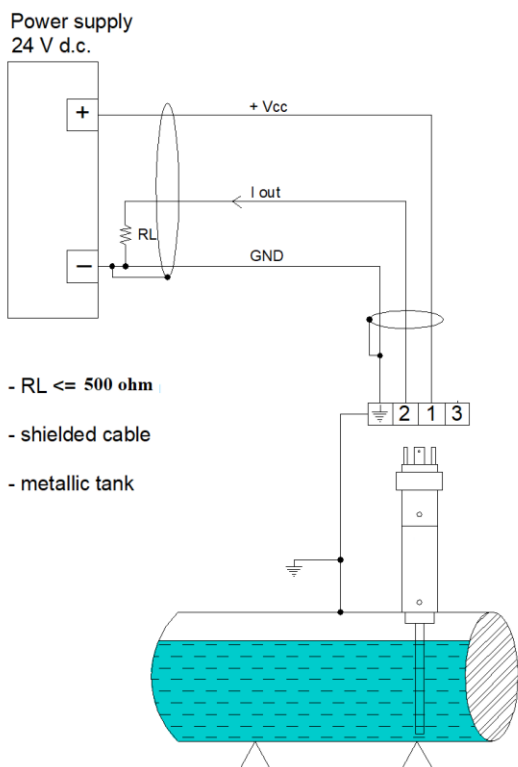

5.4 - Wiring diagram (three wires) for 451/452 with user galvanically isolated

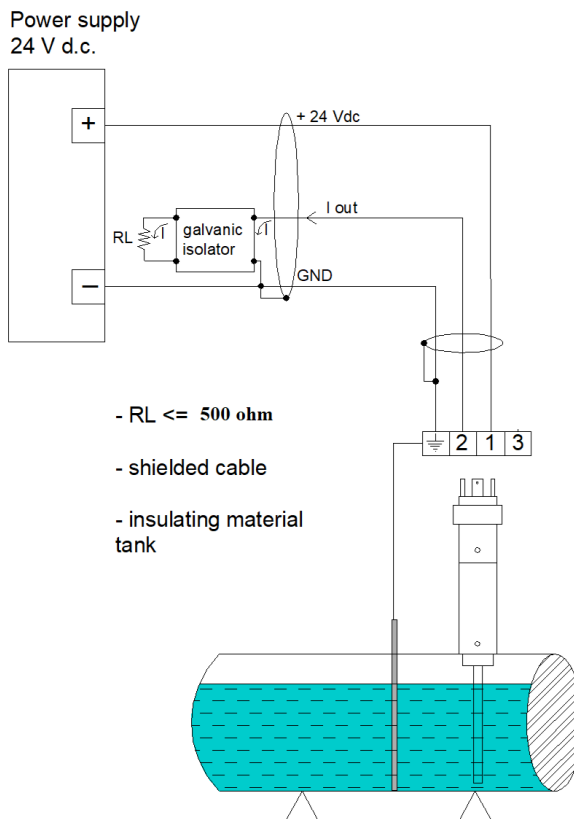
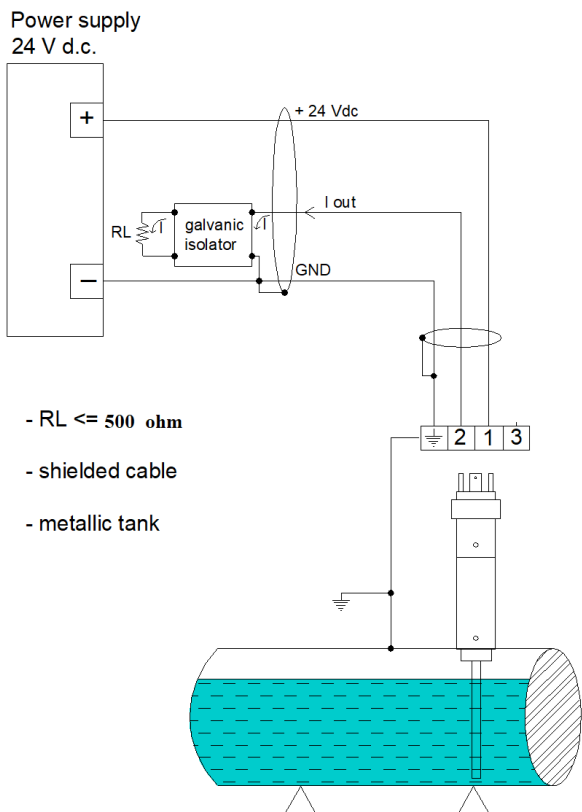



5.5 - Wiring diagram (two wires) for 450 with user not galvanically isolated

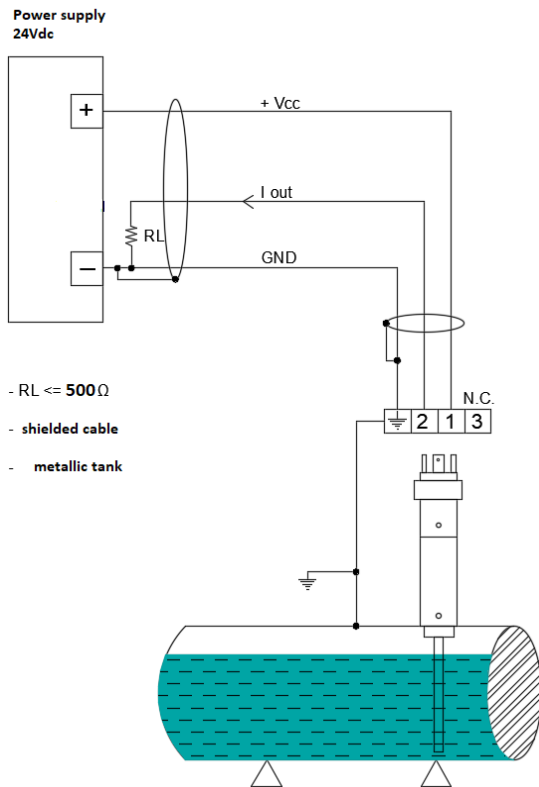

6 - Transmitter calibration (only 452 series)

The 452 (451) transmitter is supplied factory calibrated (MMT), over its whole length.

Therefore in general no field calibration by the customer is required.

However, it is possible that slight deviations in the current values are found with respect to the 4mA (empty) and 20mA (full) values, when the transmitter is placed inside small diameter pipes.

In these cases, only for 452 series, an on-site recalibration can be performed, if required.

The calibration must be carried out along the whole length, that is, the empty level must be acquired when the electrode is completely out of the liquid; while the full level must be acquired when the electrode is completely immersed in the liquid.

Proceed as follow.



7 - Buttons operation (only 452 version)

When the transmitter is switched on, at the end of its start-up phase, the LED flashes yellow for a few moments, after which the probe goes in std-by state.

Stand-by condition

In stand-by condition buttons are not read. This makes accidental button presses to be ignored.



The output current, even in stand-by condition is regularly generated.
To exit the stand-by condition, press once, simultaneously, both buttons (MODE + OK).

Operating condition

When the probe is not in stand-by condition, the two buttons has to be pressed one at time (individually), and are read with the following behavior:

MODE button: it makes the color of the land change in GREEN-BLU-YELLOW-OFF colors, with meanings explained later.

OK button: it confirms the choice made with MODE button, with a behavior explained below.

No button: if no button is pressed, the probe goes in stand-by state after about 60" and the led if not already off, switches off.

Once it has been understood the buttons operation, it is possible to go on with the empty and full level acquisition.

Note: it is not compulsory to acquire the empty level before the full level; the two acquisitions can be made in the order that is most convenient for the operator.

8 - Empty level acquisition

Ensure, using the boiler glass or other equivalent system, that the level the probe is going to acquire is the desired empty level.

Ensure that the buttons are operational. If the probe is in stand by state, take it in operating condition as described in §7.

Press MODE button a certain number of times since the led color is GREEN .

Press OK button.

The GREEN led will blink for a few moments, indicating that probe is acquiring the empty level.

At the end of the blinking sequence:

- If the led is on and GREEN , it means that the empty level has been successfully acquired.

 Empty level OK

- If the led is on and RED , it means that there has been a problem while acquiring the empty level, for example due to insufficient stability of the level during its acquisition.

 Error in empty level

9 - Full level acquisition

Ensure, using the boiler glass or other equivalent system, that the level the probe is going to acquire is the desired full level.

Ensure that the buttons are operational. If the probe is in stand by state, take it in operating condition as described in §7.

Press MODE button a certain number of times since the led color is BLUE .

Press OK button.

The BLUE led will blink for a few moments, indicating that probe is acquiring the full level.

At the end of the blinking sequence:

- If the led is on and BLUE , it means that the full level has been successfully acquired.

 Full level OK

- If the led is on and RED , it means that there has been a problem while acquiring the full level, for example due to insufficient stability of the level during its acquisition.

 Error in full level

10 - Calibration

If both empty and full level has been successfully acquired, it is possible to go on with the calibration procedure.

Calibration lets:

- to memorize in flash (permanent memory) the empty and full level just acquired, in order to keep them memorized even after a shutdown and restart of the probe.
- to make the output current of the probe be proportional to the level. Current after calibration will be 4mA in empty-level condition and 20mA in full-level condition.

Ensure that the buttons are operational. If the probe is in stand by state, take it in operating condition as described in §7.

Press the MODE button several times until the LED turns YELLOW .



Man_E_450_451_452_453 Rev. 8 del 04.05.2026

Press the OK button.

The YELLOW LED will flash for a few moments, indicating that the probe is calibrating.

At the end of the blinking sequence:

- If the led is on and YELLOW , it means that the probe has been successfully calibrated: from now on, the empty and full level are memorized in its FLASH memory and will never change unless a new calibration is performed.

  Calibration OK

- If the led is on and RED , it means that there has been a problem in the calibration procedure.

  Error in calibration

Possible causes of calibration error are:

- A full level less than or equal to the empty level.
- A full level not sufficiently higher than empty level (the difference between the two level must be 5% at least).

For both of these cases it is necessary to repeat the acquisition of empty and/or full level taking care that their mutual distance is greater than the one that caused the calibration to fail.



11 - Alarms / Warnings

The red LED , after the empty, full or calibration acquisition operation, indicates that the operation was not successful. This condition, if no key is pressed, remains for at most 60"; at the end of which the probe returns to stand-by.

This happens because these situations are similar to warnings, that is, they can be recovered in some way by the user (for example by simply repeating the acquisition operations).

If, on the other hand, a serious non-recoverable probe failure occurs, for example water infiltration in the antenna or antenna shorted to the ground, this fact would be signaled again by the lighting of the red LED, this time permanent, to indicate that probe must be returned to MMT for repair.

In this case, in addition to the red LED, the probe signals the fault by supplying a fixed current of 3mA.

12 - Notes for coupling 451⊕ 453 and 450 ⊕ 453

The 450 and 451 electronic heads, unlike the 452 electronic head, cannot be calibrated in the field.

They are supplied factory pre-calibrated (MMT) based on the length of the 453 probe to which they will be coupled.

If they were to be supplied as a spare, it is therefore necessary to know the length of the installed 453 probe to which they will be coupled. If the exact length of the 453 is not known, it is necessary to know among the 4 possible ranges (50cm; 100cm; 150cm; 190cm) the one that certainly exceeds the length of the 453 installed; in this case the 450/451 supplied as a spare will not be able to have the dynamics exactly corresponding to the length of the 453 and will lose some resolution; however, the PLC usually connected to the current output of the 450/451 will be able to normalize the signals, bringing them back into the desired range.

13 - Notes and troubleshooting

- During the empty/full level acquisition, do not touch the sensitive part of the probe with hands or other objects.
- It is recommended the use of a shielded cable, especially for long distances; the link cable must have a section which depends on the length: for cables up to 100 m long, 0.5 mmq; up to 500 m long , 1 mmq; up to 1 km long, 1.5 mmq [the resistance of every cable must always be lower than 15 Ω].
- The electric connection is for 4 ÷ 20 mA output signal, three wires with 451/452, and two wires with 450.
- Provide for periodic cleaning (usually every six months) to prevent any deposits on the Teflon coating sensor part, because this situation can cause anomalous reading of the transmitter, not corresponding to the true level of material.
- In the case of breaking of a current loop wire, the output current will be 0 mA, allowing easy service.
- In case of breaking of the covering in PTFE, the current can reach the maximum value overcoming 20mA, allowing one elementary diagnostic of the transmitter. The electronic part doesn't broken, but the covering in PTFE must be replaced.
- The 453 probe must not be immersed in liquids with turbulence: this situation can cause anomalous reading of the transmitter, not corresponding to the true level of material.
- In the case of conductive liquids, like water, the probe must do not be coated with the material in its not immersed height, for example water drop or spray: this situation can cause anomalous reading of the transmitter, not corresponding to the true level of material.
- The 453 probe must be used on its whole length; if the reading range is reduced, a possible drift effect has to be taken into account.
- In case of irregular operation, check the power supply and ground wiring; if is ok, disconnect the output of the transmitter from the user load and temporarily connect through a 100 Ω – 1/4W resistor to ground: verify that the voltage reading in parallel to that resistor changes from 0.4V to 2.0V, according to the level of the material covering the probe. Using a good digital dc mA meter it is possible to measure directly the output current, 4÷20 mA.