

999

SUPPORTS FOR MULTIPLE PROBES AND ELECTRODE-HOLDERS FOR FOOD INDUSTRY

MECHANICAL DIMENSIONS

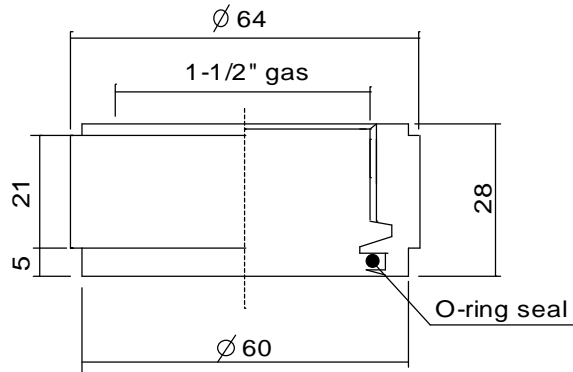

DESCRIPTION

Threaded locking rings for welding allow easy mounting and service of the probes. The o-ring seal make the probe water proof, and does not allow fouling or deposit of material to be measured between the threads.

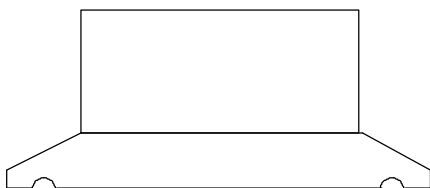

This support have the same characteristics as welding one, but the connection is *tri-clamp* type (sanitary use).

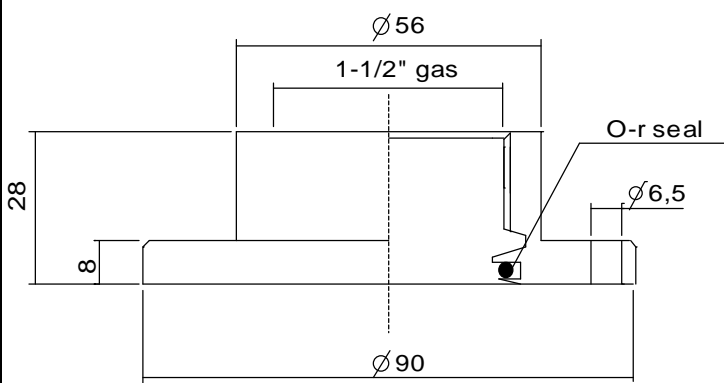

The flange support, have the same characteristics as welding one, but allows the mounting of the probes on flanged surfaces.

ORDER CODES

CODE	DESCRIPTION	TEMPERATURE	PRESSURE	CONNECTION	NOTES
999-090-00	welding support (multiple)	180 °C	25 bar	1-1/2 " stainless steel AISI 304	
999-091-00	tri-clamp support (multiple)	180 °C	25 bar	1-1/2 " stainless steel AISI 304	
999-092-00	flange support (multiple)	100 °C	25 bar	1-1/2 " pp	by order only