



# 700

## SERIES 700 MULTY-ELECTRODE HOLDER FOR FOOD INDUSTRY (for 3 ELECTRODES)

### TECHNICAL CHARACTERISTICS



- **Sensor working:** conductive
- **Probe body:** POM
- **Thread:** 1 - 1/2" gas
- **Electric wiring:** with cable inlet PG11
- **Protection grade:** IP 65
- **Electrode:** tree; AISI 303 – Ø 6mm L = 60mm
- **Covering:** 1mm thick PTFE
- **Temperature:** 100°C on the electrodes
- **Pressure:** 25 bar
- **Weight:** 360 g

### MECHANICAL DIMENSION

### WIRING DIAGRAM

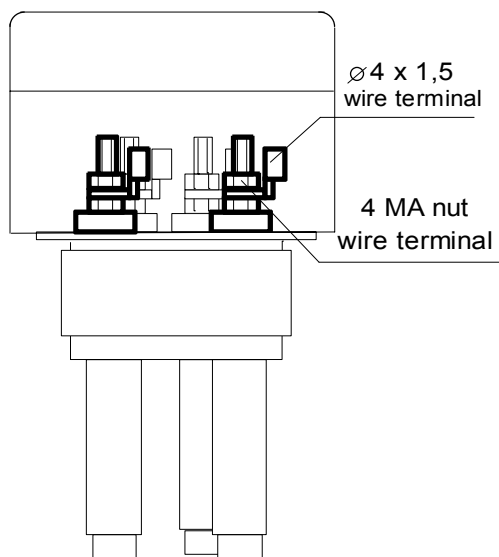
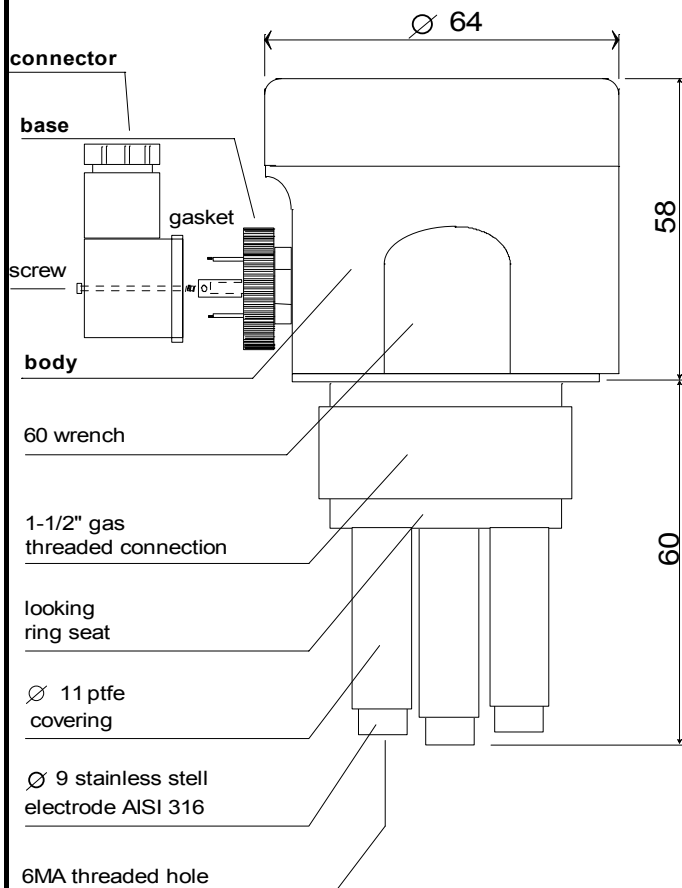

### ORDER CODES

| CODE       | ELECTRODE LENGHT | BODY                           |
|------------|------------------|--------------------------------|
| 700-032-00 | 60 mm            | POM                            |
| 700-032-10 | 60 mm            | AISI 303 stainless steel - POM |