



600

SERIES 600 SINGLE PROBE FOR FOOD INDUSTRY



TECHNICAL CHARACTERISTICS

- **Sensor working:** conductive
- **Probe body:** stainless steel / POM
- **Thread:** 1/2" gas
- **Electric wiring:** according DIN 43650A with cable inlet PG11
- **Protection class:** IP 65
- **Electrode:** AISI 316 – Ø 6mm
L = 473mm
- **Covering:** 1mm thick PTFE
- **Temperature:** 120°C on the electrode
- **Pressure:** 25 bar
- **Weight:** 320g

MECHANICAL DIMENSION

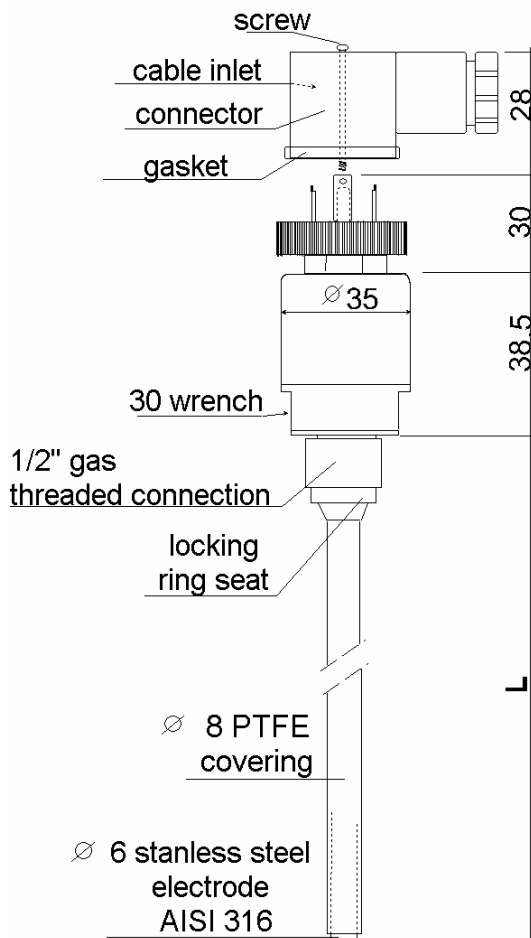

WIRING DIAGRAM

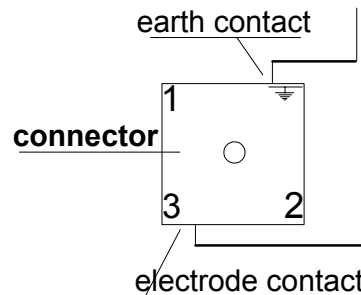

ORDER CODES

CODE	ELECTRODE LENGHT	BODY
600-050-00	473 mm.	Inox AISI 303 - POM
600-050-20	473 mm.	Inox AISI 316 - POM
600-100-00	973 mm.	Inox AISI 303 - POM
600-100-20	973 mm.	Inox AISI 316 - POM