



## Continuous level transmitter, series 440

### INSTRUCTION MANUAL - English

Thank you for purchasing 440 series level transmitter.

Before using the device, please read carefully this manual, and keep it in a safe place, for future use.

#### 1 - Description

440 series are capacitive continuous level transmitters for solid and liquid materials. The material to be controlled can be good electric conductor, or insulating, like water, oil, diesel fuel, powders in general. They cannot be used with inflammable liquids, but they can be used with diesel fuel at  $T < 55^{\circ}\text{C}$ . Rugged and compact, the 440 series give an output current signal, proportional to the material level.

#### 2 - Technical characteristics

• dimensions are in mm:

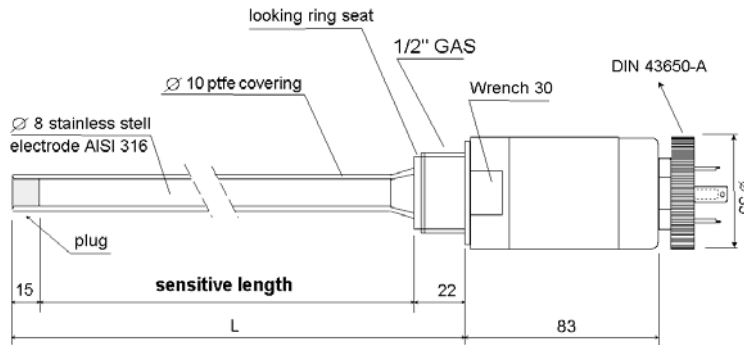

Drawing #1

- Power supply:  $10 \div 30$  Vd.c. according to the resistive load (drawing #2)
- Output  $4 \div 20$  mA;  $R_{\text{max}} = 0 \div 500\Omega$  2 wire configuration according to the power supply (drawing #2)

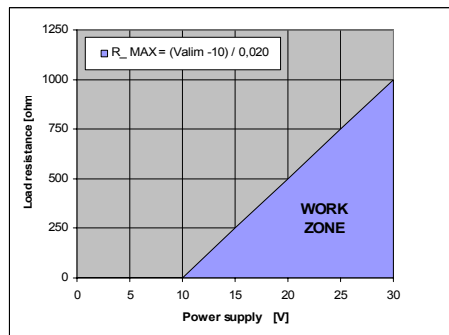

Drawing #2

- absorption: 0.25 VA
- thread: 1/2" gas
- electric wiring: DIN 43650-A
- weight: 800 g [ per L = 1000 mm ]
- protection class: IP65
- protect against power supply reversal
- covering 1mm thick PTFE food compliant
- stainless steel body
- pressure  $\leq 25$  bar
- temperature:  $120^{\circ}\text{C}$  on the electrode



- precision: 0,5% f.s. after calibration
- plug: 15mm not-sensitive end, at the bottom
- working: once the transmitter has been installed and calibrated, according to the following instructions, it generates a normalized  $4 \div 20$  mA d.c. signal proportional to the material level in the tank.

### 3 - Installation and use

#### 3.1 - Mechanical assembly

- The transmitter must be installed according to the following drawing:

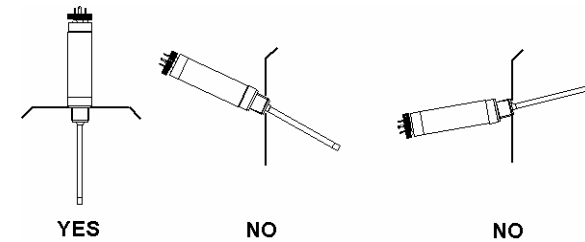

Drawing #3

The transmitter must be mounted in the tank, in vertical position, so that the tank sides aren't in contact with the probe.

The maximum measurable level must be about 95% of the probe height.

The minimum measurable level must be about 5% of the probe height.

#### 3.2 - Electric wiring

- Before powering the device, be sure that the power supply voltage is in the range  $10 \div 30$  V d.c.
- Wire the transmitter to the power supply and to the current loop receiver, according the following drawing (2-wire connection):

If the tank is metallic, do not interpose flange or electric insulating gaskets (like teflon) between the thread  $\frac{1}{2}$ " of the probe and the surface/body of the tank; the ground of the tank must be in contact with the thread  $\frac{1}{2}$ " of the probe. Anyway, connect electrically the terminal GND of the transmitter with the tank ground:

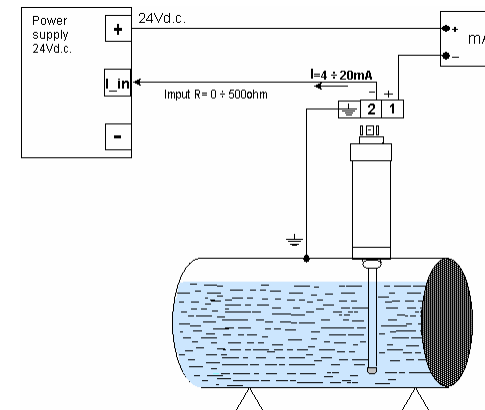

Drawing #4



If you want to measure the output current, insert a mA meter (0 ÷ 24mA d.c.) in series to one of the two wire of connection. (drawing #4)

If the tank is in electric insulating material, you must insert inside the same tank a metallic electrode (good electric conductor) that has to be always in contact with the material to be measured, also to the least desired level; this electrode must have the same length of the probe and diameter 4mm, and must be electrically connected to the terminal GND of the transmitter; for such a connection and for that of the power, refer to the following drawing:

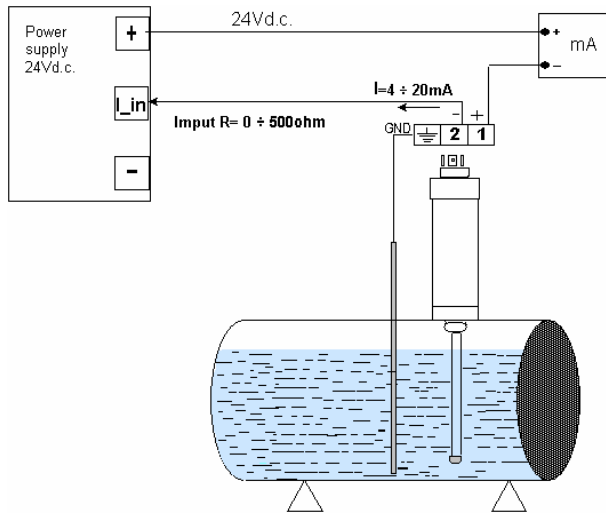

Drawing #5

If you want to measure the output current, insert an mA meter (0 ÷ 24mA d.c.) in series to one of the two wire of connection. (drawing #5)

### 3.3 - Calibration

**ATTENTION:** During test or calibration, DON'T TOUCH with hands or other objects the sensitive part of the probe, but grasp the transmitter on the cover that include the electronic part.

The calibration must be done with a digital multimeter (mA-meter).

- First, unscrew the cover of the electrical connector and only after unscrew the top cover of the transmitter, to avoid to roll up too much wires to the inside. A vertical electronic small board will appear with 2 trimmers of regulation and a signalling led lamp, according to the following drawing:

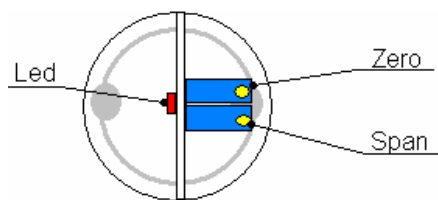

Drawing #6



- Connect the dc mA meter in series to one of the two wires of connection.
- Put the level of the material to be measured to the desired minimum: the probe should be covered on the end for at least 1 cm.
- Slowly rotate the trimmer ZERO, until the current read by the mA meter is 4 mA (at this value the red led lamp will have the minimum brightness).
- Put the level of the material to be measured to the desired maximum: the probe should be covered on the top for at least 1 cm.
- Slowly rotate the trimmer SPAN, until the current read by the mA meter is 20 mA (at this value the red led lamp will have the maximum brightness).
- After calibration, the output current depends on the level height as in the following drawing:

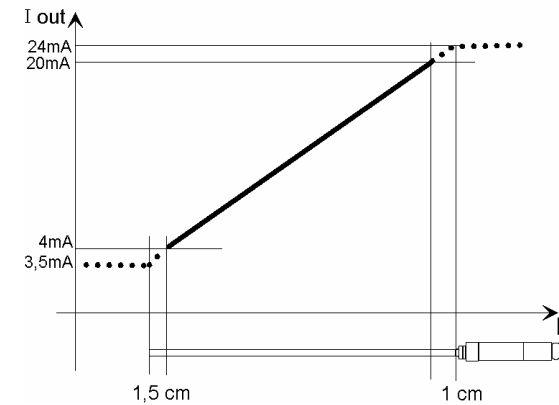

Drawing #7

### 4 - Notes and troubleshooting

- NB: don't touch the sensitive part of the probe with hands or other objects.
- The link cable must have a section which depends on the length: for cables up to 100 m long, 0.5 mmq; up to 500 m long, 1 mmq; up to 1 km long, 1.5 mmq [the resistance of every cable must always be lower than 15 Ω].
- In the case of breaking of a wire, the output current will be 0 mA, allowing easy service.
- In case of breaking of the covering in PTFE, the current can reach the maximum value overcoming 20mA, allowing one elementary diagnostic of the transmitter. The electronic part doesn't broken, but the covering in PTFE must be replaced.
- In the case of conductive liquids, like water, the probe must do not be coated with the material in its not immersed height: this situation can cause anomalous reading of the transmitter, not corresponding to the true level of material.
- In case of irregular working, check the power supply and ground wiring; disconnect the output of the transmitter from the user load and temporarily connect it to 0 V of the power supply through a 500 Ω – 1/4W resistor: verify that the voltage reading in parallel to that resistor changes from 2 V to 10 V, according to the level of the material covering the probe. Using a good digital dc mA meter it is possible to measure directly the output current, 4 ÷ 20 mA.